

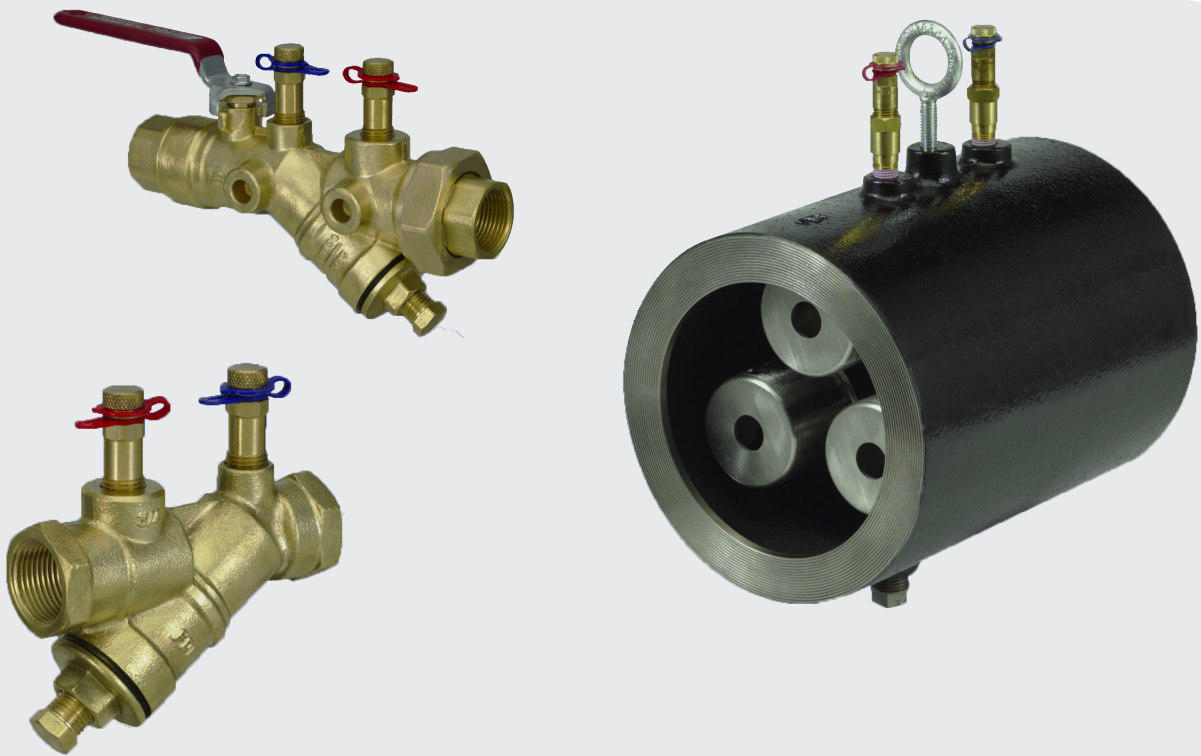

AutoFlow



Automatic Flow Control Valves

Engineering
GREAT Solutions

Benefits of Automatic Balancing

System equipment, such as chillers and individual terminal units, is the heart of any HVAC system. Extreme care and time is dedicated to their selection and performance criteria. However, without proper flow through these units, their efficiencies and heating or cooling transfer capabilities are altered.

By specifying automatic balancing, the designer is assured that the system is accurately and dynamically balanced. This means that all components will perform as specified regardless of changes. With automatic flow regulators, the terminal units will not exceed design flow even after modifications or additions to the system. In a proportionally (manually) balanced system, such changes can cause overflow unless adjustments are made at risers, branches and terminals.

Automatic balancing offers a number of other benefits such as: pump energy savings, lower head requirements and less balancing labor. These and other features are discussed in detail in the following sections.

Balancing Accuracy

Automatically balanced systems are certified to be accurate within five percent. Manually balanced systems are generally considered to be only 15 percent accurate.

Saves Pump Energy

Proper waterside balancing can typically save ten percent of the Brake Horse Power (BHP) when compared to an unbalanced system. This is why almost every hydronic system is balanced either manually or with AutoFlow. AutoFlow valves achieve system balance as soon as the pumps are turned on.

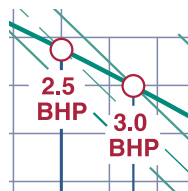

AutoFlow units save additional pump energy by preventing overflow compared to manually balanced two or three-way controlled coils. Modulating three-way valves can overflow by 40 percent and manually balanced two-way valves can overflow 20 percent to 30 percent when some of the valves are closed or at part load. As a rule of thumb, automatic balancing can save ten percent of the installed BHP when compared to a manually balanced system.

Lower Head Requirements

AutoFlow valves with a 2-32 psi spring range add only 4.6 feet to the calculated pump head. Manual circuit setters typically add ten feet of head (three devices). A five foot lower head requirement can help reduce the size of the pump selected.

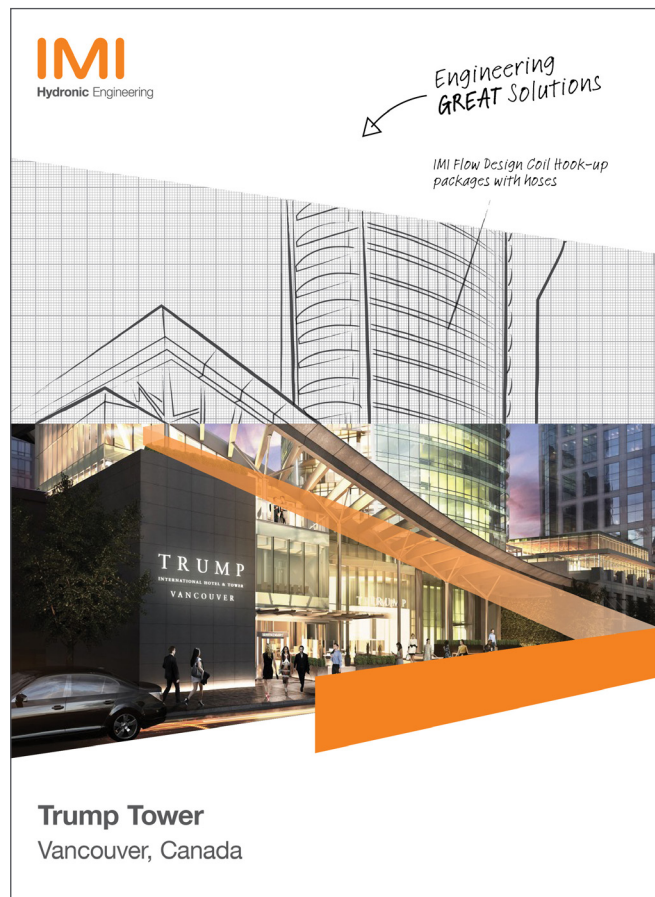

Accurate and dynamic balancing is assured throughout any building with the use of AutoFlow valves.



Products from IMI Flow Design are designed and manufactured in a facility whose quality management system is registered to ISO 9001:2000

Best for Variable Speed Pumping

The dynamic AutoFlow valve adjusts to lower differential pressures to provide design flow at any pump speed. When pump speed is reduced in a direct return system, header pressures are reduced and some interior manually balanced coils will experience underflow.

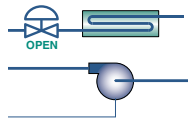

See page 12

Tamperproof Design

With AutoFlow valves, the design GPM for each coil is maintained for the life of the building. Manual balancing devices are commonly used as shut-off valves and require a memory stop to maintain the set position. Because the memory stop can be adjusted, the “set position” can be lost, which will increase system flow and operating BHP.

The seven different cartridge sizes assure optimum flow regulation for energy savings, balancing accuracy and design flexibility.

Cartridge Selection

1/2" AutoFlow Cartridge can control rates as low as 0.5 gpm with precision

Patented Hybrid Port

Stainless Steel Wear Surfaces

Engineering GREAT Solutions

Lower Balancing Labor

The coil GPM should be verified. With AutoFlow valves, this can be done in a few minutes by reading the differential pressure across the valve. It requires much less time than to manually balance each coil.

Space Saving

The AutoFlow balancing valve is compact when compared to a circuit setter which requires five-to-ten straight pipe diameters at the inlet. AutoFlow does not require any inlet straight pipe and can be close coupled to an ATC valve which will save valuable space and insulation costs.

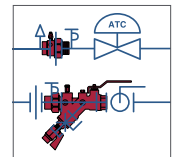

See page 5

Design Flexibility

Direct return circuiting can save 30 percent in distribution piping costs. However, many times these systems are very difficult to manually balance. AutoFlow can provide perfect system balance without having to visit each coil two-to-three times as is typical with manual balancing.

Equipment may be added to a system easily without the need to rebalance each existing coil.

System Design with Automatic Balancing

There are two major differences in overall system design when using automatic instead of manual balancing. A system with automatic flow regulators requires fewer balancing devices than a manually balanced system. With automatic balancing any overhauling is distributed to the AutoFlow devices at the terminal units; in a manually balanced system the overhauling appears at the triple-duty valve at the pump discharge.

Manual Balancing System

A correctly designed manual system requires that balancing devices be placed in series at each of the subsystems; i.e. terminals, branches, risers, mains and the pump discharge. The system cannot be proportionally balanced without metering and throttling devices at each of these points. Final system balance is obtained by throttling the valve at the pump discharge and/or trimming the pump impeller to reduce the flow to the design point.

Automatic Balancing System

In a correctly designed automatically balanced system, automatic regulators are placed only at the terminal equipment such as fan coils and air handlers. They are not required, nor are they recommended, for branches, risers, mains or at the pump discharge. AutoFlow valves can be placed in series with each chiller or boiler to prevent overflow.

It is not necessary to throttle the valve at the pump discharge as with manual balancing because each AutoFlow valve has dynamically absorbed the overhauling.

To measure this overhauling, determine the differential pressure at the most remote AutoFlow valve and subtract the five feet required for its operation. This excess pressure head can be reduced by trimming the pump impeller or reducing the pump RPM in variable speed systems.

Balancing Valve on Coil Return

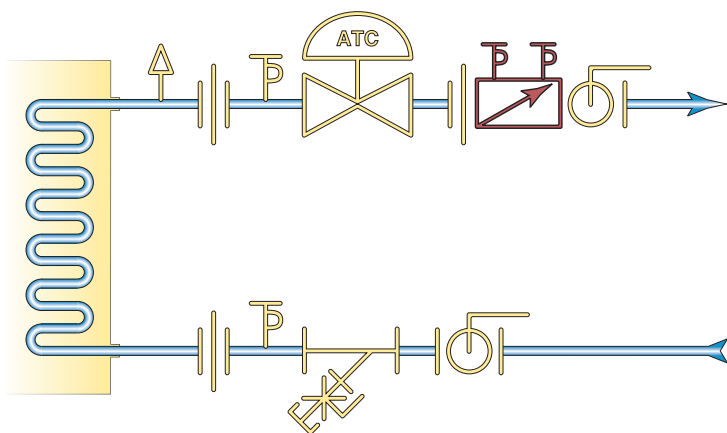

Required Balancing Devices in a Properly Balanced System

In accordance with standard recommendations.

Location	Automatic	Manual
Terminal	yes	yes
Branch	no	yes
Risers	no	yes
Mains	no	yes
Pumps	no*	yes

* Except for Primary / Secondary or Modular Chiller

At The Terminal

The preferred location for manual or automatic balancing valves is the return side of the coil, as shown in the detail in the Balancing Valve on Coil Return diagram above. The return side is recommended by ASHRAE and is preferred by many engineers because it will:

- Minimize air entrapment
- Reduce noise problems
- Decrease the possibility of ATC valve cavitation

Common Objections to Automatic Balancing

Engineers Are Reluctant to “Fix the Flow”...

Autoflow ensures design flow rates, all the time.

The tamperproof nature of the AutoFlow sets the design for the life of the building. It cannot be changed easily by well intentioned maintenance personnel. However, if the flow requirement changes, a different AutoFlow cartridge with a new GPM can be installed in a few minutes. It is especially easy on Models AC and YR where the cartridge can be installed without breaking the main piping. For new construction projects, should there be addenda or minor changes in capacity required before completion, FDI will replace unused cartridges for up to 10% of total quantity of valves on each project without charge. Installation of the exchanged cartridges is the responsibility of others. Contact your FlowDesign representative for further information.

They Plug Up...

A strainer protects the Autoflow valve, the ATC valve and the coil.

AutoFlow valves don't plug if they are piped as recommended with an inlet Y-strainer. The strainer also protects the coil and the ATC valve. The strainer is low-cost protection for these important components.

Y-strainers are generally recommended with a blowdown valve to ease servicing. The inlet strainer is recommended for sizes 1/2" to 1" and is encouraged for 1 1/4" and up.

They Waste Energy with Their High Pressure Drops...

Autoflow saves pump energy, and avoids the cost of additional valves and labor.

AutoFlow valves add 4.6 feet to the calculated pump head. Circuit setter type devices typically add ten feet or more. The circuit setter requires manual devices on the coil, branch, riser and main. This series of units adds ten feet and many times 15 feet or more to the pump head.

They Cost Too Much...

Autoflow is the most affordable first-cost performance improvement you can provide.

Automatic Balancing saves balancing labor, pump BHP, and reduces energy consumption. A typical 3/4" complete coil hook-up (including ATC valve) can cost an owner well over \$300 installed. An Autoflow regulator adds less than 10% to this cost. The expenditure can easily be recovered with reduced pumping costs (achieved by lowering operating head) and preventing overflow. Using AutoFlow instead of manual balancing saves 1/2 hour in balancing time per coil, and will pay for itself many times over the life of the project through savings in pump BHP and energy consumption!

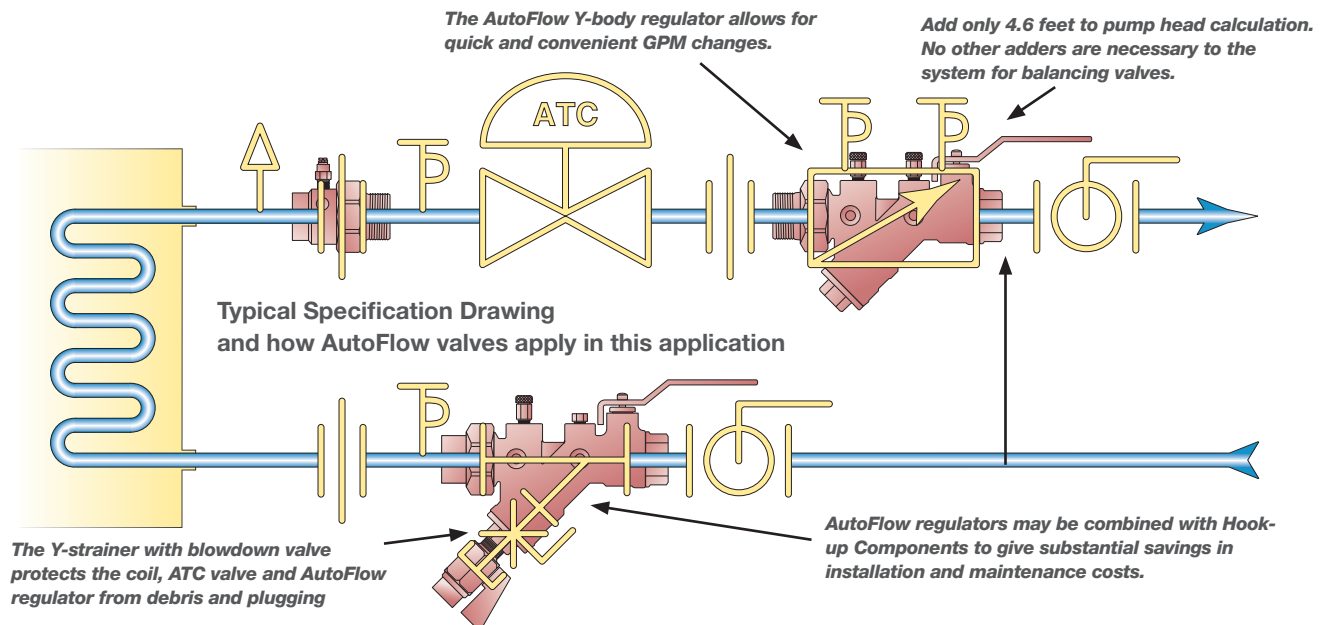

Design of the AutoFlow Cartridge

At the heart of every AutoFlow valve is a unique and patented cartridge design that provides unparalleled control and reliability. Take a closer look at the AutoFlow cartridges and how they deliver a controlled response to changes in differential pressure.

The AutoFlow valve's piston and body are CNC (Computer Numeric Control) machine milled and turned. This state-of-the-art technology maintains tolerances down to ± 0.0005 inches and assures accuracy and repeatability of flow. A fine machined calibration thread allows precision adjustment of the exact spring preload and free height which achieves design start-up (two psi to seven psi).

The patented consolidated variable side porting and single orifice end hole provide the absolute maximum orifice size and minimum flow restriction at a given pressure differential. The large end port boosts low pressure flow through the cartridge, utilizing the vena contracta occurring directly behind the variable side ports.

The engineering and manufacturing processes employ a total CAD/CAM system, producing seven different cartridge sizes for optimum flow regulation. These cartridges are capable of controlling flows from 0.5 to 25,000 gallons per minute. Wear surfaces are of different hardness, maximizing lubricity between the two surfaces and greatly extending wear life. The patented consolidated porting offers solids handling capability unexcelled in the industry.



The unique patented design of the 1/2" AutoFlow cartridge can control very low flow rates with precision, providing a guaranteed $\pm 5\%$ of design flow.

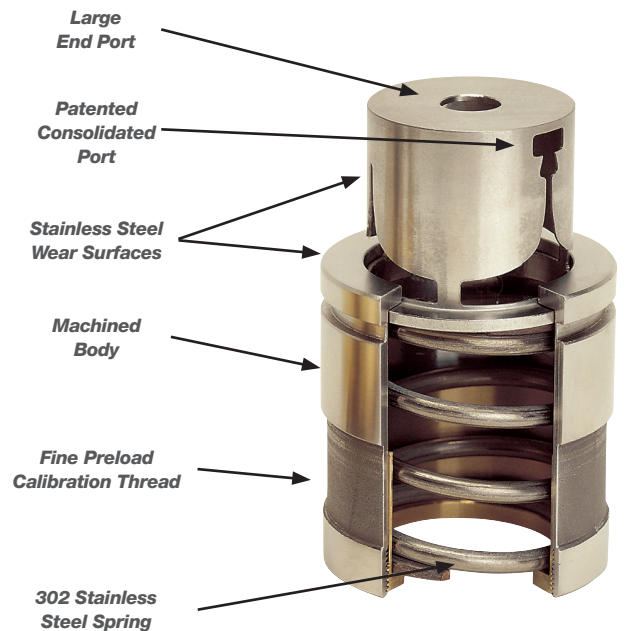
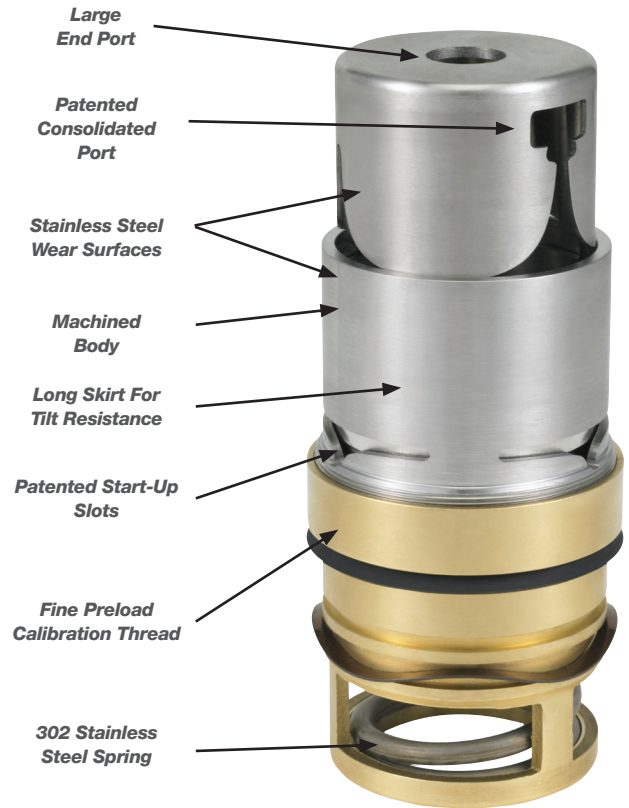

Piston Reaction to Varying Differential Pressures

Below the AutoFlow Control Range with ATC Modulating Flow

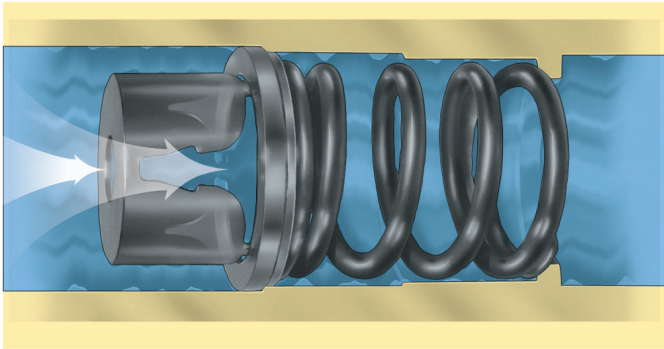

The differential pressure is below the minimum needed to activate the AutoFlow piston. It is fully extended and acts as a fixed orifice with a Cv of .71 times design flow (2-32 range) or .45 times design flow (5-60 range). The ATC is controlling the GPM in this zone.

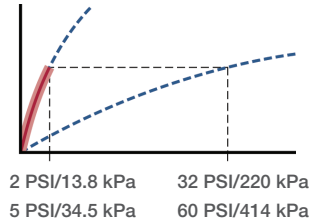

Within the AutoFlow Control Range with ATC Wide Open

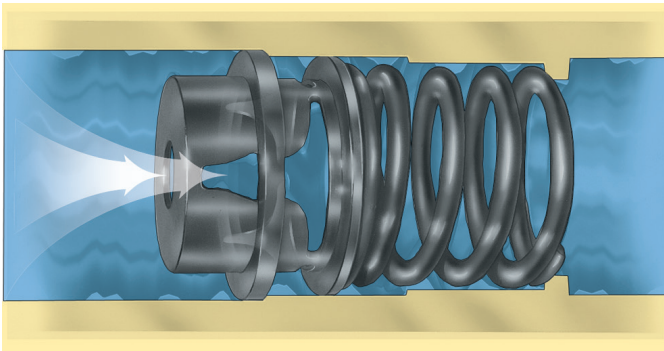

AutoFlow piston now responds to changes in differential pressure by repositioning the variable side orifices to maintain design flow \pm five percent. At approximately 50 percent of control range, the consolidated side port now handles all flow through the variable orifice. The Cv is variable in this range and is a function of piston position.

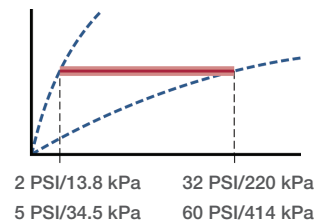

Above the AutoFlow Control Range with ATC Wide Open

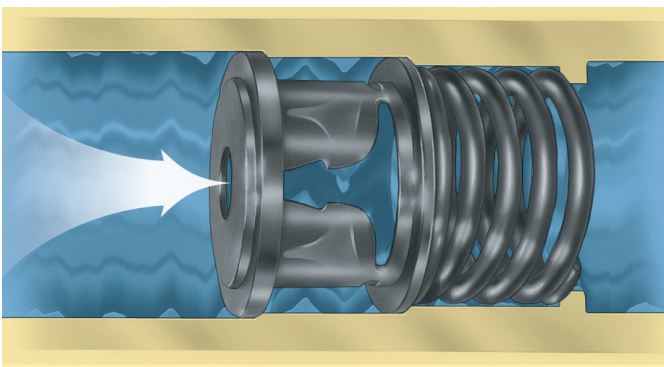

Now fully retracted, only the AutoFlow piston's end port is exposed. The regulator functions as a fixed orifice and will react to increased pressure differential with increased flow in accordance with the formula: $GPM = C_v \sqrt{\Delta P}$. Fixed Cv of the valve is now .18 times design flow (2-32 range) and .13 times design flow (5-60 range). A 25 percent "over range" (32 psi to 40 psi) increases the flow by only 12 percent!

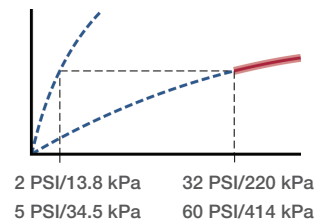

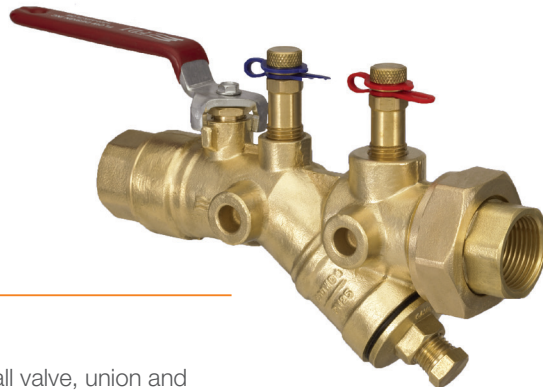

Model AC

This AutoFlow combination valve has an integral ball valve, union and Y-shaped body for easy removal of the flow cartridge without breaking the main piping. Cartridge removal is similar to that of Y-strainer. The easy access provides for inspecting or changing the cartridge. The AC comes with two pressure/temperature ports as shown. The ball valve and union provide a compact unit that saves space and insulation costs. Extensions are available if the insulation exceeds 1" thick.



Model YR

The Y-pattern body used for the Model YR is the industry standard. This common sense concept provides simple access to the flow cartridge yet still gives the valve a tamperproof quality. Cartridge removal is similar to that of a Y-strainer. This easy access provides for inspecting or changing the cartridge. The YR comes with two pressure/temperature ports.

Model WS

This wafer-style AutoFlow fits between standard ANSI Class 150 or 300 flanges. The ductile iron body is supplied with a lifting lug, drain plug, two pressure/temperature test ports and flange rods and nuts. This unit is available in sizes 2 1/2" to 30". The maximum rating for sizes 2 1/2" to 14" is 600 PSIG at 250° F; maximum rating for 16" to 30" is 225 PSIG at 250°F. Multiple flow cartridges are utilized to provide the specified GPM.



Energy Savings with Three-Way Valves

Three-way valves are not constant flow devices. When three-way valves are manually balanced, there can be a substantial overflow. With AutoFlow regulators there are no overflows, and no overflow means energy saved. The diagrams here show how the three-way valves are balanced and how AutoFlow saves energy...

Manual Balancing Requires the Following Steps

1. A differential pressure gauge is placed on the manual balance valve.
2. The three-way ATC valve is driven to the full open position with all the flow through the coil.
3. The manual balance valve is adjusted to achieve the “design flow” and the memory stop is locked in place. The D.P. gauge is left in place.
4. The ATC valve is driven to the full by-pass position.
5. The ball valve in the by-pass is adjusted to achieve design flow through the by-pass and the memory stop on the ball valve is locked in place.

Manual Balance Three-Way Coil

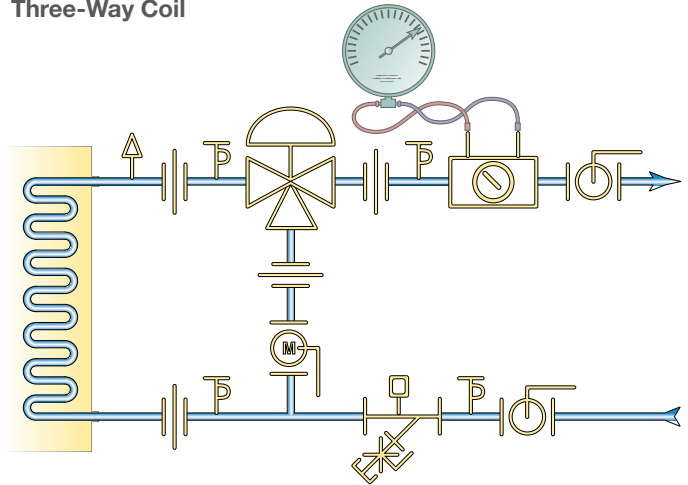

Steps Required in Setting up the AutoFlow Circuit

1. The proper AutoFlow valve, factory-labeled for the specific terminal unit and GPM, must be installed as shown.
2. Design flow is achieved as soon as the pump is turned on.
3. Verification of the design flow can be achieved by reading the differential pressure across the AutoFlow valve. A reading above two psi and below 32 psi indicates that the design GPM is flowing.

Automatic Balance Three-Way Coil

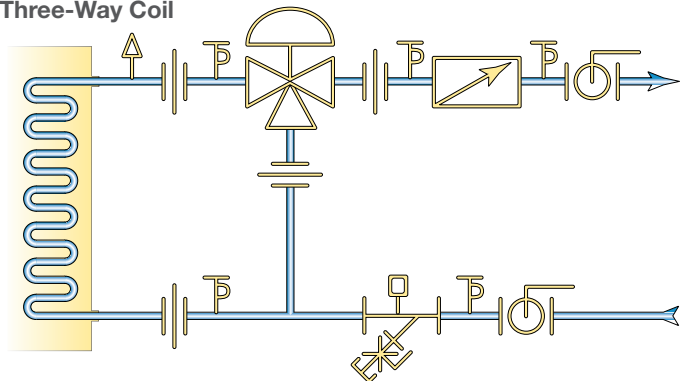

Overflow Wastes Energy

The graph to the right shows that the manual balance points are at the extreme ends of the ATC valve operating range. At midrange, where the valve operates most of the time, the overflow can range from 10-50 percent with manual balancing. The AutoFlow regulator keeps the flow at design GPM regardless of the valve’s position. This saves 10-20 percent of the BHP for the life of the building.

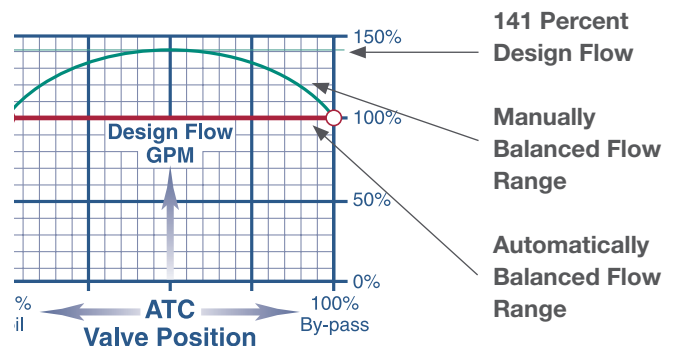

Energy Savings with Two-Way Valves

Two-way valves reduce the amount of water pumped, which saves energy. Used in conjunction with AutoFlow regulators, even less water is pumped, saving even more energy.

Typical Direct Return System

The system below has ten coils – all balanced with AutoFlow. Assume that each coil is equipped with a ten GPM AutoFlow valve. The system's total flow will be 100 GPM.

Now, assume that the system is at 50 percent load with five of the two-way valves closed. Immediately, the pump will back up the curve and will deliver 50 GPM. The remaining five open circuits do not overflow, even though the head pressure increases.

With manual balancing valves instead of AutoFlow, the open circuits will overflow. The amount of overflow depends on the pump curve, but it can be 20-50 percent more than the AutoFlow balanced system.

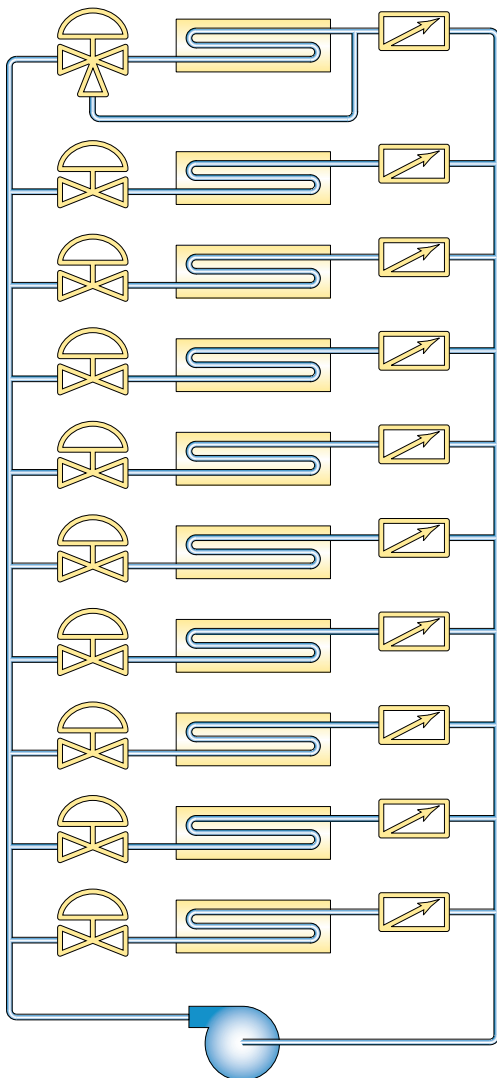

Overflow Wastes Energy

The typical pump curve below shows how energy can be saved by preventing overflow on two-way valve systems! At 50 percent load, the manually balanced system can overflow by 20-50 percent. AutoFlow regulators prevent this overflow and provide a true variable volume water system which can save 10-20 percent of the BHP for the life of the building.

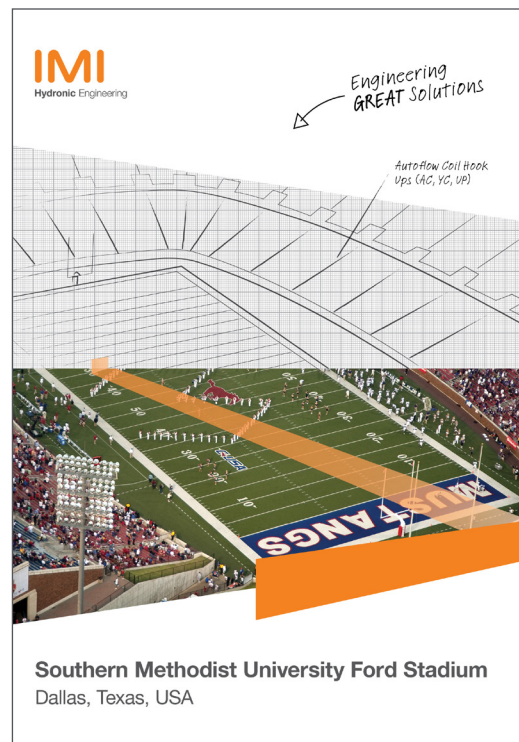
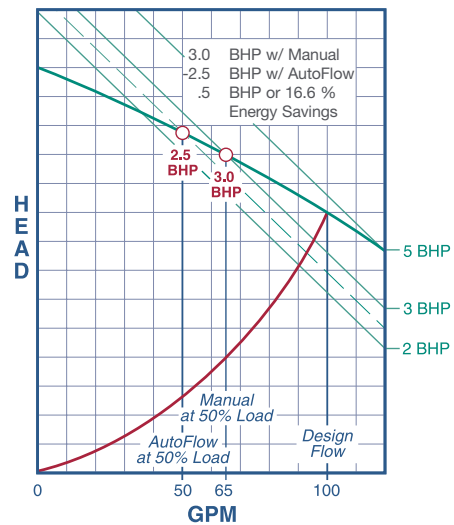

Variable Speed Pumping

Manual balancing will not work with direct return circuited, variable speed systems. As the two-way valves close, the header pressures decrease. This pressure reduction causes the problems described below...

Manual Balancing

At 100 percent flow, the balancing valves absorb increasing amounts of head the closer the coil is to the pump. The balancing valve at Terminal A is set at a pressure drop of 77 feet to provide an equal balance.

The second diagram shows the same system at 50 percent flow with all ATC's modulated equally, except Terminal A which is wide open. At half flow, the distribution losses are 25 percent. This reduces the pump head to 50 feet and the differential pressure across Terminal A is reduced to 48 feet.

The wide open ATC valve at Terminal A is calling for full flow, but there is a 31 percent flow deficit. The reason is that this terminal was balanced with 102 feet of differential pressure for full flow and now only has 48 feet.

Automatic Balancing

With AutoFlow regulators installed, the 100 percent flow conditions are exactly the same as a manually balanced system. Also, the drop caused by the balancing valve in each air handler is the same for both manual and automatic devices.

However, the situation differs at 50 percent flow when the ATC valve at Terminal A opens calling for full flow. Because the ATC and the coil require pressure drops of 15 feet and ten feet, only 23 feet remain ($48 - 15 - 10 = 23$). The AutoFlow regulator automatically adjusts to the 23 foot drop to prevent overflow.

The AutoFlow regulator has adjusted from 77 feet to 23 feet differential pressure, yet still maintains the same flow rate. When the variable speed pump head pressure decreased, it adjusted automatically. This dynamic valve fits the needs of the variable speed balancing perfectly!

The diagrams to the right represent a ten story building with identical air handlers on each floor. Each air handler coil has a ten foot drop and the ATC valve has a 15 foot drop at design flow. The distribution pipe loss is four feet between floors on the supply and the return. The variable speed sensor is placed at the top floor and is set for 30 feet to provide full flow to that air handler at all times.

Full System Flow
Manual or Automatic

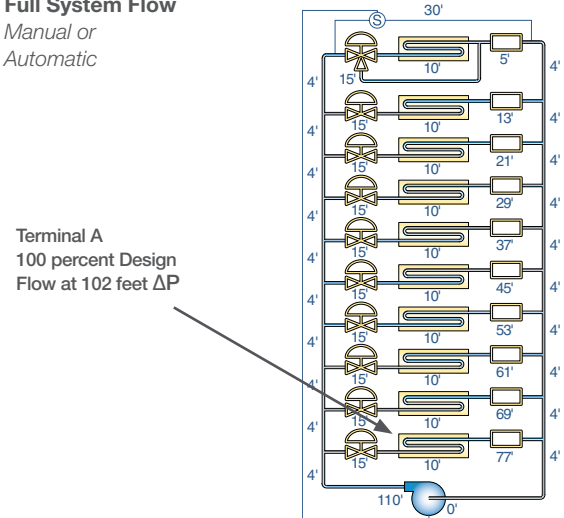

Terminal A
100 percent Design Flow at 102 feet ΔP

50 Percent System Flow
Manual

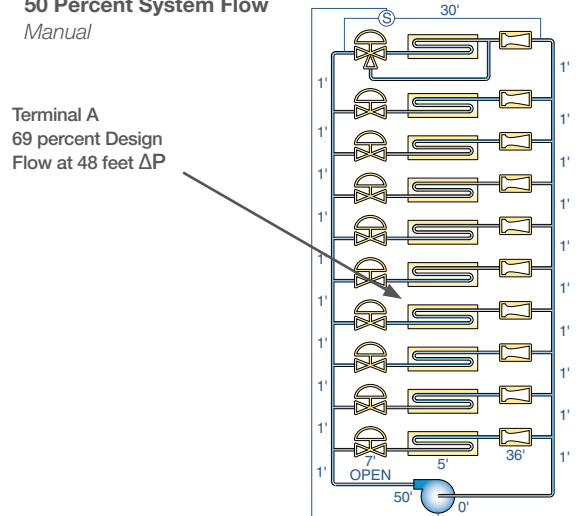

Terminal A
69 percent Design Flow at 48 feet ΔP

50 Percent System Flow
Automatic

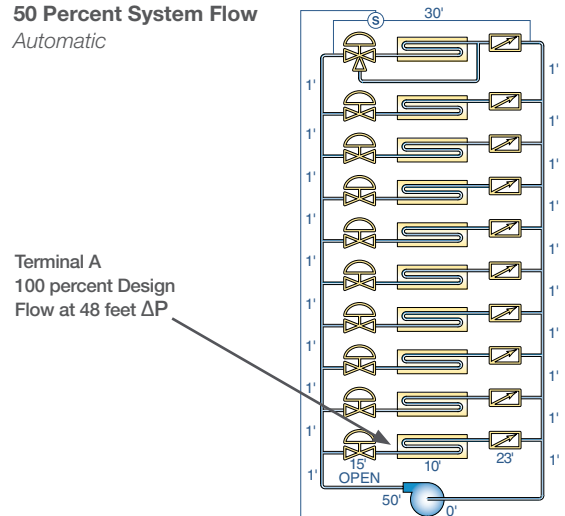

Terminal A
100 percent Design Flow at 48 feet ΔP

Selecting the Proper AutoFlow Valve

Review Your Current Specification for “Automatic Flow Control Valves”

Use the specifications below as your guide.

Manufacturers

- IMI Flow Design, AutoFlow or approved equal. Models YR, AC, WG, WS, WB, WR, or WT.

Design

- The GPM for the automatic flow control valves shall be factory set and shall automatically limit the rate of flow to within five percent of the specified GPM over at least 95 percent of the control range.
 - For 1/2"-2 1/2" Y-bodies, the flow cartridge shall be removable from the housing without the use of special tools to provide access for regulator changeout, inspection and cleaning without breaking the main piping. (Access shall be similar to that provided for removal of a 1/2"-3/4" T strainer).
 - Pump Head Requirement - The permanent pressure loss added to the pump head shall not exceed seven feet of water column.
 - Each valve shall have two pressure/temperature test ports, arranged to provide a reading of differential pressure across the flow limiting mechanism.
 - All automatic flow control devices shall be supplied by a single source and certified flow tests, witnessed by a professional engineer, shall be available.
1. Five-year product warranty and free first-year cartridge exchange, up to 10% of the total units ordered.

Construction

- The internal wear surfaces of the valve cartridge must be stainless steel.
- The internal flow cartridge body shall have machined threads so the spring free height may be compensated for without the use of fixed shims. A crimped sheet metal design is not acceptable.
- The internal flow cartridge shall be permanently marked with the GPM and spring range.
- For 1/2" through 2" pipe sizes: An assembly shall consist of a DZR brass Y or T type body, integral brass body ball valve and "O" ring type union. IMI Flow Design Model AC or equal.
- For 2 1/2" and larger flanged connections: Ductile iron body suitable for mounting wafer style between standard 150# or 300# flanges. The long flange bolts and nuts shall be provided

with each control valve. IMI Flow Design Model WS or equal.

- All valves shall be factory leak tested at 100 psi air under water.

Minimum Ratings

- 1/2" through 2" pipe size: 400 PSIG at 250°F
- 2 1/2" through 14" pipe size: 600 PSIG at 250°F
- 16" through 30" pipe size: 225 PSIG at 250°F

Flow Verification (choose one):

- The differential pressure across the Automatic Flow Control Valve shall be measured for flow verification and to determine the amount of system over heading or under pumping.
- The flow shall be verified by measuring the differential pressure across the coil served or the wide-open temperature control valve and calculating the flow using the coil or valve Cv.
- A Venturi shall be installed on the supply side of the coil to verify flow.

Test Kit:

- An AutoFlow Dual Hose Meter pressure test kit shall be supplied to verify flow and measure overheating. The kit shall consist of a 4 1/2" gauge with three ball valves @ 150 psi and 1,000 kpa, two ten foot hoses with shut-off valves, a pair of GA 18 standard P/T adapters, plastic bleed hose and carrying case.

Installation:

- Install automatic flow control valves on the return lines of coils as indicated on the plans. A balancing valve on supply side is not acceptable.
- The standard ports and handles shall clear 1" thick insulation. Handle and port extensions are required for over 1" thick insulation. Do not insulate flow control valves used on heating coils.
- Install, on the supply side of coils, a Y-strainer (20 mesh) with brass blowdown valve with 3/4" hose end connection with cap. Inline (basket) strainer is not acceptable.

Selecting the Proper AutoFlow Valve

Review Your Coil Piping Schematic

Make sure the detail reflects the following:

- The balancing valve is on the return side of the coil. It should be located just before the exit isolation valve.
- A Y-strainer with a blowdown valve located on the coil inlet.
- Adequate unions, P/T ports and air venting.

Symbols Key...

	Pressure/Temperature Test Port		Manual Calibrated Balance Valve Pump
	Manual Air Vent		AutoFlow Control Valve
	Automatic Air Vent		Check Valve
	Pump		Strainer with hose end drain

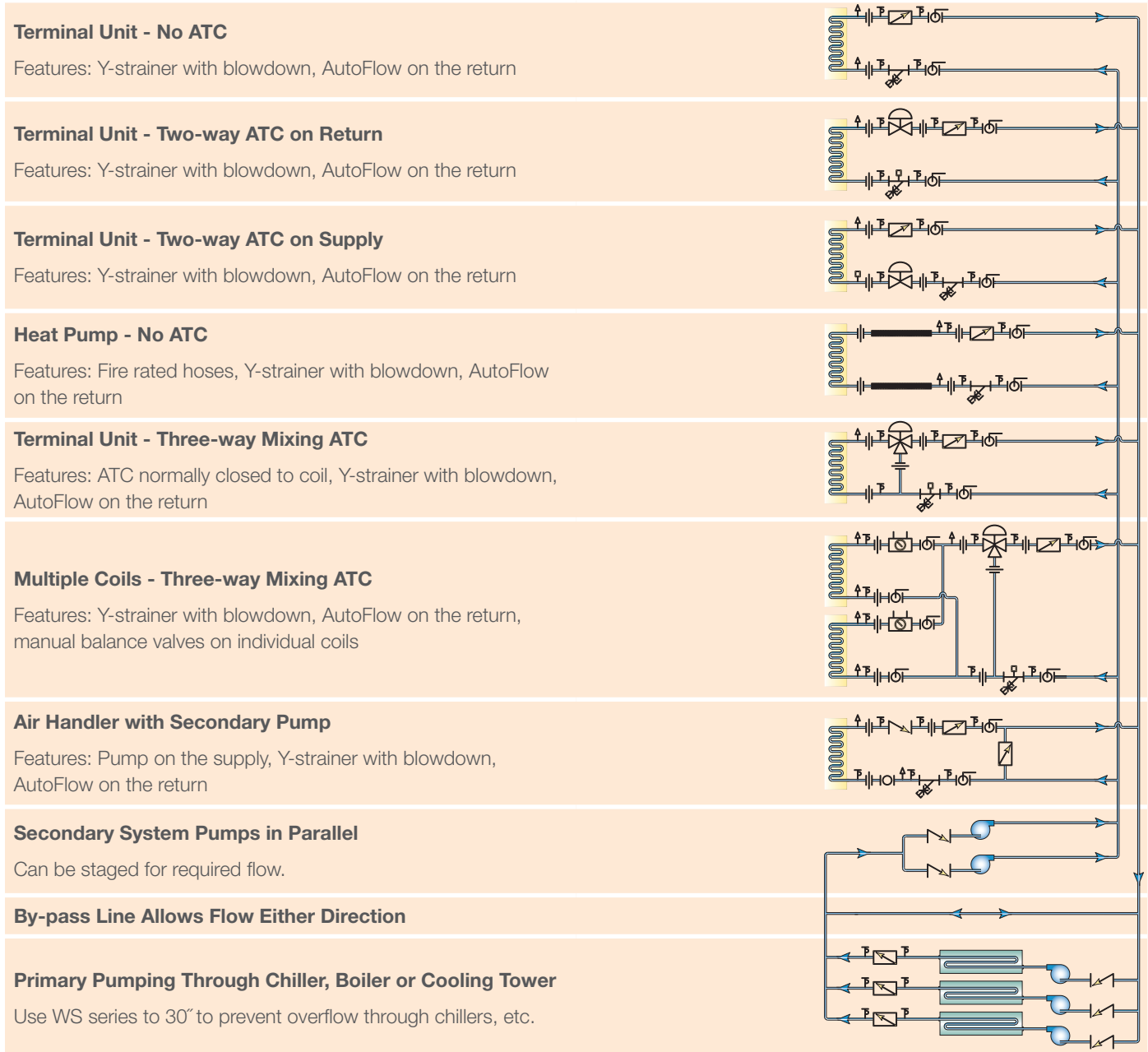

Selecting the Proper AutoFlow Valve

Specify the Coil Runout Pipe Sizes

Refer to the ASHRAE recommendations shown in the chart below. Some designers prefer to use 80 percent of the ASHRAE maximum.

ASHRAE Recommended Maximum GPM

Nominal Size	Type L Copper	Sch. 40 Pipe	ASHRAE Criteria
1/2"	2.8	3.8	Maximum Velocity four feet/sec.
3/4"	5.9	6.5	
1"	10	11	
1 1/4"	16	18	
1 1/2"	23	25	
2"	39	41	Maximum Loss four feet/100 feet
2 1/2"	78	72	
3"	130	160	
4"	270	275	
6"	775	775	

Select the AutoFlow Valve Spring Range

Two spring ranges are available for all AutoFlow valves: 2 to 32 psi and 5 to 60 psi. The first number is the differential pressure (ΔP) needed to achieve design flow. The second is the maximum ΔP where the design flow will be maintained. Following are some general rules on the selection of the spring range. In most cases the amount added to the calculated pump head is 4.6 feet (2 psi X 2.3 feet/psi).

- For direct return systems, if the total pump head is less than 110 feet, the 2-32 range can generally be used for all units.
- On reverse return systems the 2-32 range can be used for all units.
- For direct return systems with a total pump head exceeding 110 feet, the 5-60 range should be used only on units close to the pump to maintain control.

To calculate the spring range required for a specific terminal unit:

Estimate the losses due to -

- pump accessories such as suction diffusers, check valves, etc.
- distribution pipe loss to the terminal unit
- terminal coil, ATC, and Y-strainer drops at design flow.

Add a, b, and c and then subtract from the total pump head.

If less than 74 feet, use the 2-32 range. If greater than 74 and less than 138 feet, use the 5-60 range.

Example: The total pump head is 132 feet and the total of a, b and c is 35 feet. $132 - 35 = 97$ Use the 5-60 range since the remaining pump head is greater than 74 feet (32 psi).

Select the AutoFlow Cartridge Flow Rate

Using the chart below, find the available flow according to the size valve required and the system design flow. If the required flow falls between two available flows, round to the nearest flow listed.

Size	PSID	Available Flow Rate (GPM) by Cartridge
1/2"-3/4"	2 - 32	0.33, 0.5, 0.67, 0.75, 0.88, 1.0, 1.1, 1.25, 1.5, 1.75, 2.0, 2.25, 2.5, 3.0, 3.5, 4.0, 4.5, 5.0, 6.0, 7.0, 8.0
	5 - 60	1.0, 1.5, 2.0, 2.5, 3.0, 4.0, 5.0, 6.0, 7.0, 8.0, 9.0, 10, 11, 12
1"-1 1/4"	2 - 32	0.5, 0.75, 1.0, 1.25, 1.5, 1.75, 2.0, 2.25, 2.5, 3.0, 3.5, 4.0, 4.5, 5.0, 6.0, 7.0, 8.0, 9.0, 10, 11, 12, 13, 14, 15, 16, 17, 18, 19
	5 - 60	1.0, 1.5, 2.0, 2.5, 3.0, 4.0, 5.0, 6.0, 7.0, 8.0, 9.0, 10, 11, 12, 13, 14, 15, 16, 17, 18, 19, 20, 21, 22, 23, 24, 25, 26, 27
1 1/2"-2"	2 - 32	5.0, 6.0, 7.0, 8.0, 9.0, 10, 11, 12, 13, 14, 15, 16, 17, 18, 19, 20, 22, 24, 26, 28, 30, 32, 34, 36, 38, 40, 42, 44, 46, 48, 50
	5 - 60	8.0, 9.0, 10, 11, 12, 13, 14, 15, 16, 17, 18, 19, 20, 21, 22, 23, 24, 25, 26, 27, 28, 30, 32, 34, 36, 38, 40, 42, 44, 46, 48, 50, 52, 54, 56, 58, 60, 62, 64, 66, 68, 70
2 1/2"	2 - 32	9.0, 10, 11, 12, 13, 14, 15, 16, 17, 18, 19, 20, 22, 24, 26, 28, 30, 32, 34, 36, 38, 40, 42, 44, 46, 48, 50, 52, 56, 60, 64, 68, 72, 76, 80
	5 - 60	13, 14, 15, 16, 17, 18, 19, 20, 21, 22, 23, 24, 25, 26, 27, 28, 30, 32, 34, 36, 38, 40, 42, 44, 46, 48, 50, 52, 54, 56, 58, 60, 62, 64, 66, 68, 70, 72, 76, 80, 84, 88, 92, 96, 100, 104, 108, 112, 116, 120

Flows for sizes 3"-30" are available in increments of 5 GPM for PSID 2-32 and 5-60, and 10 GPM for PSID 3-20, 5-40 and 7-45.

Size	PSID	Max GPM	Size	PSID	Max GPM	Size	PSID	Max GPM
3"	2 - 32	135	8"	2 - 32	945	14"	2 - 32	2565
	5 - 60	170		5 - 60	1190		5 - 60	3230
	3 - 20	200		3 - 20	1400		3 - 20	3800
	5 - 40	250		5 - 40	1750		5 - 40	4750
	7 - 45	300		7 - 45	2100		7 - 45	5700
4"	2 - 32	270	10"	2 - 32	1485	20"	2 - 32	4320
	5 - 60	340		5 - 60	1870		5 - 60	5440
	3 - 20	400		3 - 20	2200		3 - 20	6400
	5 - 40	500		5 - 40	2750		5 - 40	8099
	7 - 45	600		7 - 45	3300		7 - 45	9600
6"	2 - 32	540	12"	2 - 32	2025	30"	2 - 32	9450
	5 - 60	680		5 - 60	2550		5 - 60	11900
	3 - 20	800		3 - 20	3000		3 - 20	14000
	5 - 40	1000		5 - 40	3750		5 - 40	17500
	7 - 45	1200		7 - 45	4500		7 - 45	21000

NOTE: 5", 16", 18" and 24" flows available, see specific submittal.

Selecting the Proper AutoFlow Valve

Select an AutoFlow Model

After studying your coil piping schematic, choose the AutoFlow model which best fits your needs:

1/2" to 2"

Model AC - Brass Y-shaped body for easy cartridge access with integral isolation ball valve, union and two ports. This combination valve saves space and lowers total cost.

Model YR - Brass Y-shaped body for easy access. Includes two pressure/temperature test ports.

2 1/2" to 14"

Model WS - Ductile iron wafer-style body which fits between standard 150# or 300# flanges. Includes two pressure/temperature test ports.

16" to 30"

Model WS - Wafer style steel body which fits between standard 150# flanges. Includes two pressure/temperature test ports.

NOTE: For additional models, please reference your IMI Flow Design manual or visit us at www.flowdesign.com.

Select the AutoFlow Valve Spring Range

Use the example below as a guide. *Other AutoFlow models are available. Please see catalog.

Equip No.	Coil GPM	AutoFlow GPM	Runout Size	Coil Size	ATC Size	Spring Range	Model No.
FC-1	.8	.75	1/2"	1/2"	1/2"	2-32	AC0050L
FC-2	1.2	1.25	1/2"	1/2"	1/2"	2-32	AC0050L
FC-3	1.4	1.50	1/2"	1/2"	1/2"	2-32	AC0050L
FC-4	3.1	3.00	3/4"	1/2"	1/2"	2-32	AC0075L
FC-5	4.4	4.50	3/4"	1/2"	1/2"	2-32	AC0075L
FC-6	6.1	6.00	1"	3/4"	1/2"	2-32	AC0100L

